

MODEL AD-2000

Automatic Voice/Pager Dialer System with Verification

Not just the next generation...it's the next millennium!

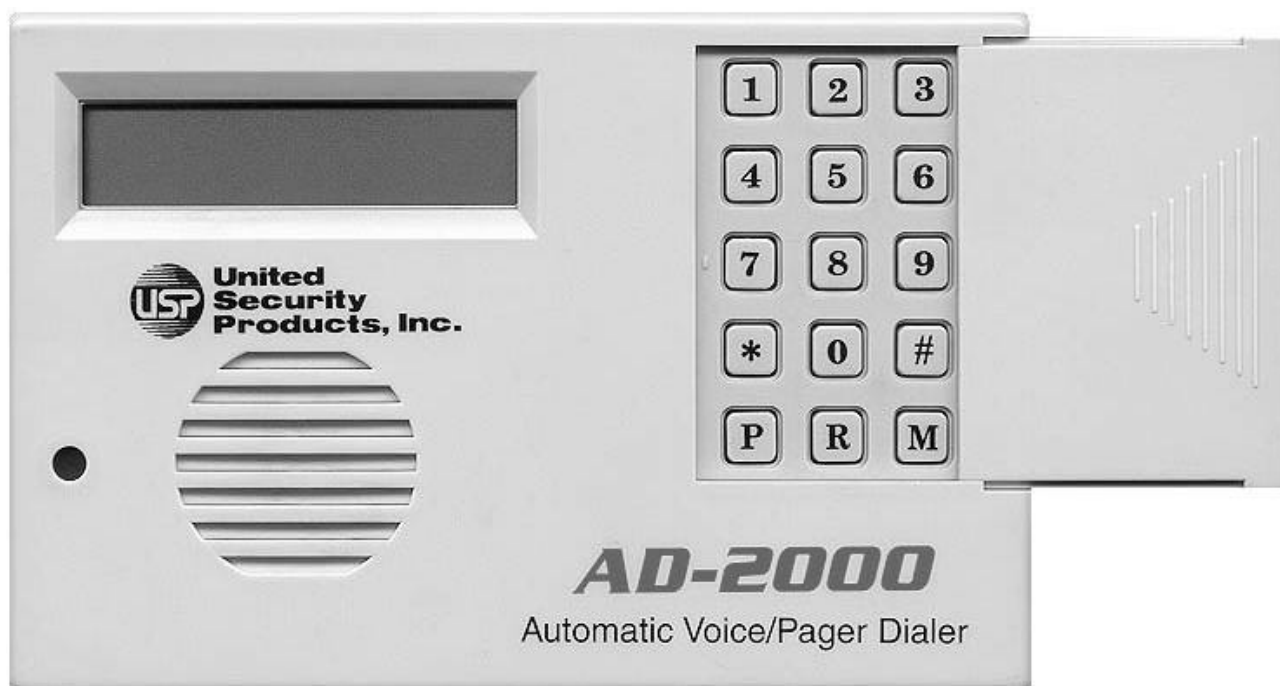

Versatile * Full-featured * Easy to Program

2-way Listen in Verification

Operates with all alarm systems

Ideal stand-alone dialer

Provides reliable emergency notification 24 hours a day



**United
Security
Products, Inc.**

**PLEASE READ THIS MANUAL BEFORE PROGRAMMING AND USING THE UNIT.
IMPORTANT: SAVE THESE INSTRUCTIONS**

MODEL AD-2000

Owner's Manual and Operating Instructions The Automatic Voice/Pager Dialer System *For The Next Millennium*

Congratulations!

Thank you for purchasing United Security Products, Inc.'s Model AD-2000 - the "smartest", most comprehensive automatic voice/pager security dialer available. Representing an exciting new level of achievement, the AD-2000 combines technologically advanced features, ease of programming and reliable operation in a compact, unobtrusive dialer completely compatible with any security alarm system. Installation and hookup are quick and easy, whether installed in conjunction with normally open, normally closed dry contact or voltage activation sensors. The unit can also function as a stand-alone device, by simple connection to an ordinary telephone jack. The keypad cover glides on and off for added attractiveness and security.

How It Works

The AD2000 dialer features busy-line and no-answer detection to ensure prompt transmission of up to 4 prerecorded messages delivered sequentially to as many as 8 standard telephones, cellular phones, voice and/or numeric pagers. Messages to both local and long-distance calls can be transmitted. When activated, the dialer instantly begins calling the numbers in sequence, delivering each message 1 to 3 times in a row, in accordance with the pre-selected number of dialing attempts.

The AD-2000 is extensively programmable, offering personalized customization to fulfill virtually any residential or business requirement. Plain-English prompts walk the user through the process in a timely manner.

Programming options abound, allowing the user to:

- Store up to 8 telephone/pager numbers.
- Choose 1-9 calling efforts for the numbers dialed.
- Select 1-3 message repeats.
- Record a variable combination (maximum: 7) of instructional outgoing messages (total elapsed time: 51 seconds).

Program up to 4 separate input channels with individually enable/disable, entry/exit delay and activation options (Normally Open (N.O.), Normally Closed (N.C.))

(dry contact or voltage activation) including momentary and continuous activation for each).

Further individualize each channel by selecting the delay times, telephone/pager numbers to be dialed and the specific outgoing messages to be played.

Please Familiarize Yourself With These Instructions Before Installation/Operation. This guide describes how to program and operate the dialer. We strongly recommend that you read the entire manual before attempting to use the unit.

To enhance ease of programming and operation, this guide includes:

- A Programming Sample/Quick Setup review on page 13 with a corresponding Program Planner.
- A Blank Program Planner on page 14. One copy of this Planner should be kept in a safe place by the end user. A separate copy should also be retained by the installer.

We are happy to provide a full measure of security reassurance and peace of mind with the Model AD-2000. For information about other innovative United Security Products equipment, call (800) 227-1592.

For Technical Service And Support: Call (858) 597-6677 * Fax (858) 455-0036

E-mail usp@ix.netcom.com

Monday – Friday * 7:30 AM – 4:00 PM PST

THIS PACKAGE CONTAINS:

- 1 ea. MODEL AD-2000
- 1 ea. PHONE CABLE
- 1 ea. INSTRUCTION MANUAL
- 4 ea. 1K RESISTORS

TABLE OF CONTENTS

Section	Page number
Package contents.....	3
Panel Displays.....	4
Installation Hookups: Alarm Panel.....	5
Installation Hookups: Stand Alone.....	6
Programming the Dialer.....	7-11
Overview.....	7
Programming Phone/Pager Numbers.....	8
Programming Auxiliary Information.....	9
Programming/Recording OGMs.....	10
Programming Channels.....	10-11
Testing Your System.....	11
Operating Your System.....	12
Additional Features.....	12
Programming Example.....	13
Sample Program Planner.....	13
Blank Program Planner.....	14
Specifications.....	15
Dialer Accessories.....	15
Important Information.....	16

PANEL DISPLAYS

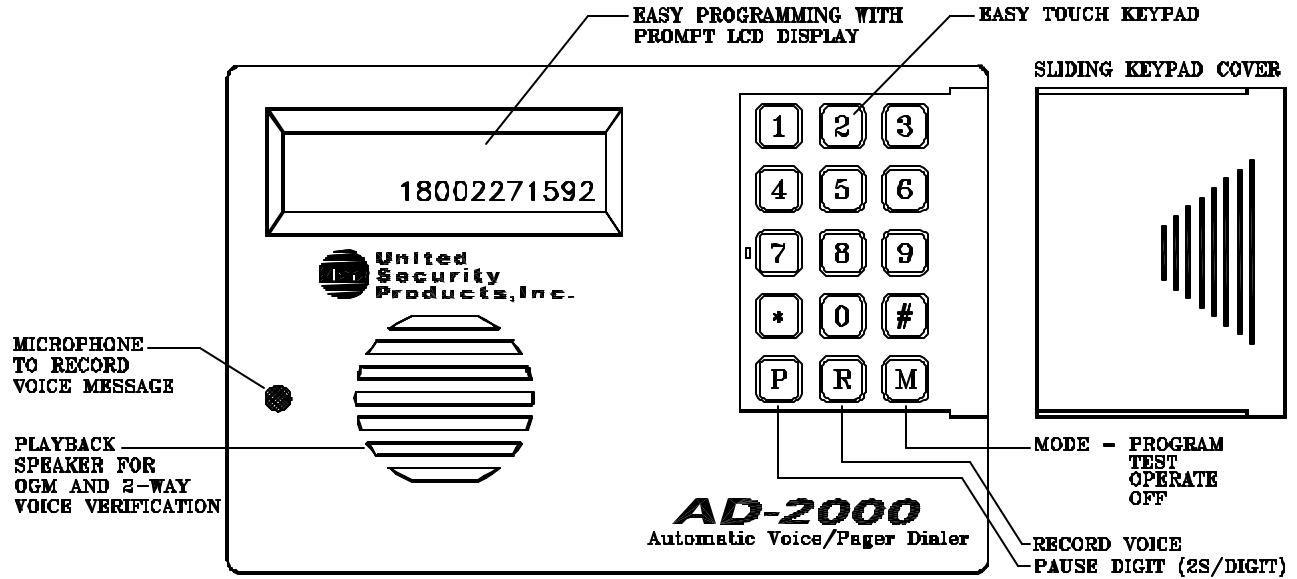

AD-2000 FRONT VIEW

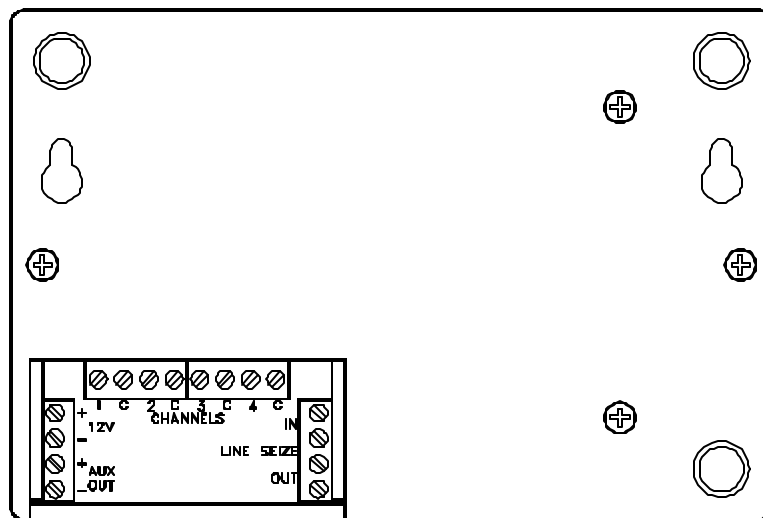

AD-2000 BACK VIEW

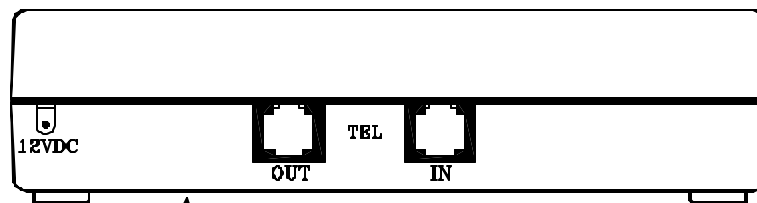
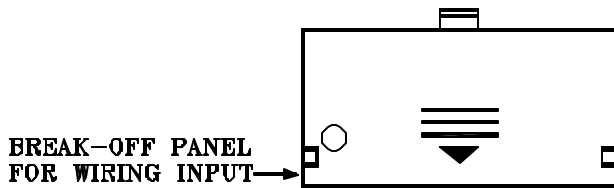

TERMINAL ACCESS ON BACK

AD-2000 TOP VIEW

AD-2000 INSTALLATION HOOKUPS

Alarm Panel

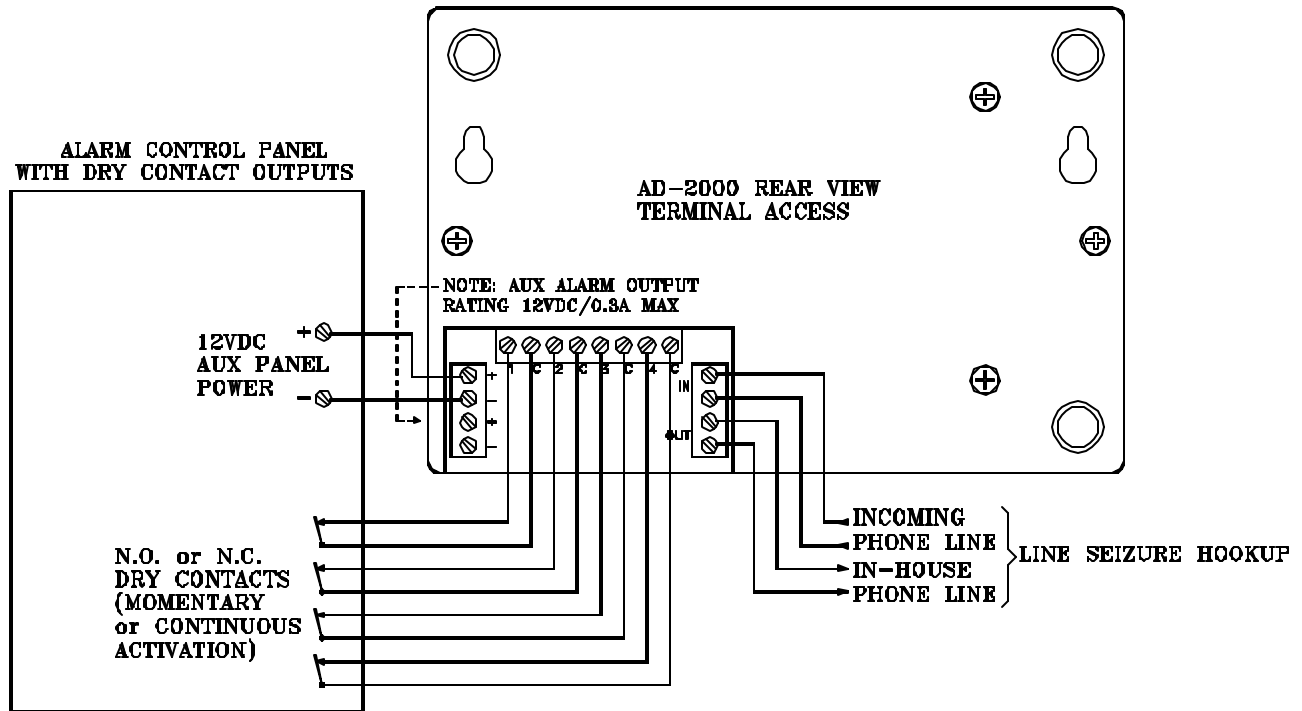

DRY CONTACT ALARM PANEL INTERFACE

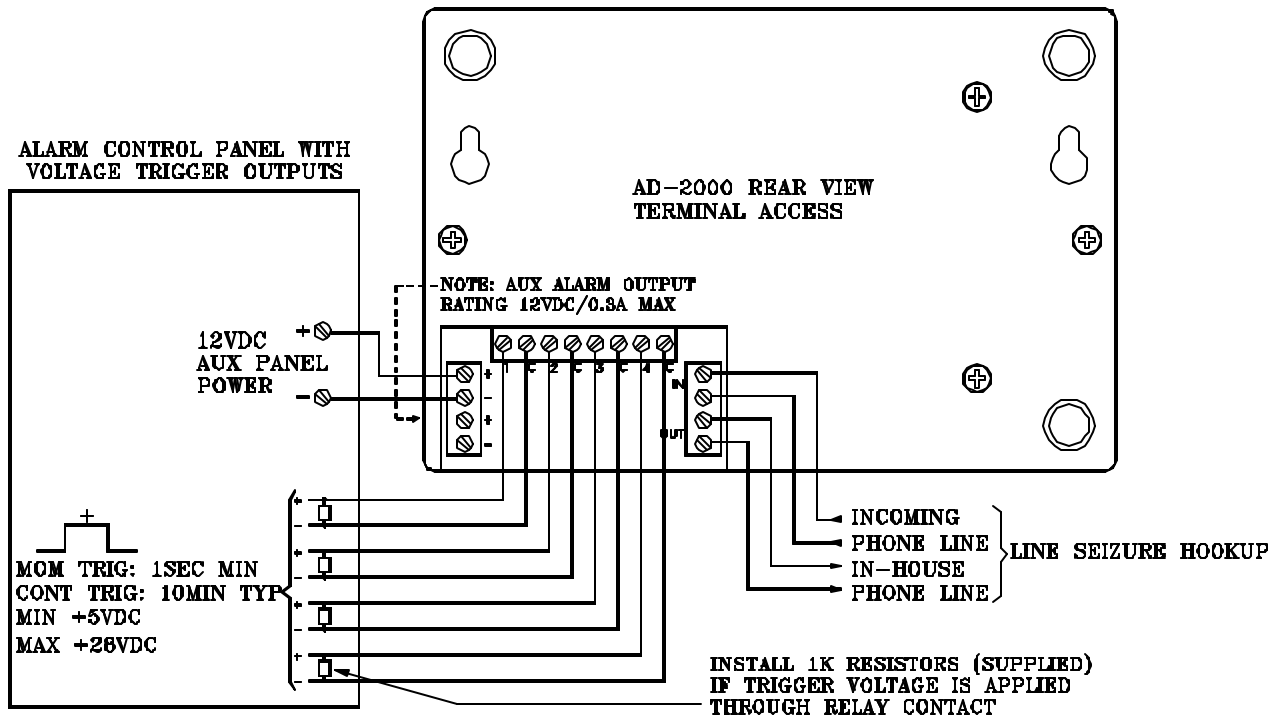

VOLTAGE TRIGGER ALARM PANEL INTERFACE

AD-2000 INSTALLATION HOOKUPS

Stand Alone

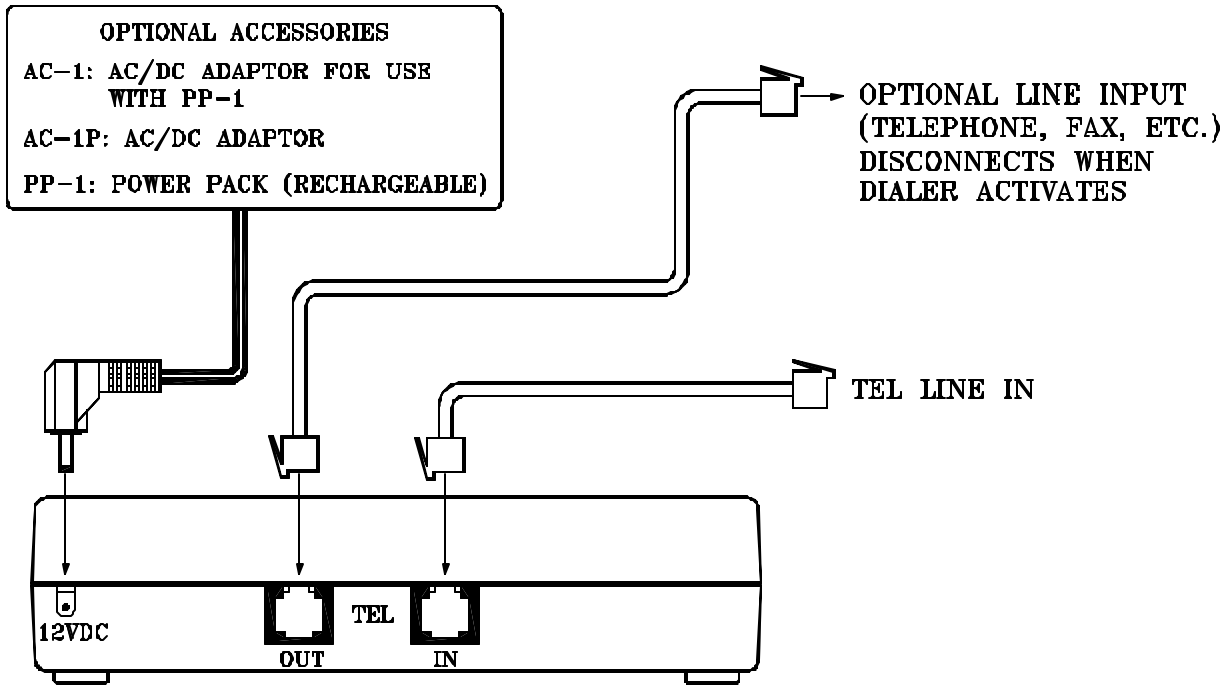

POWER & TELEPHONE LINE INTERFACE

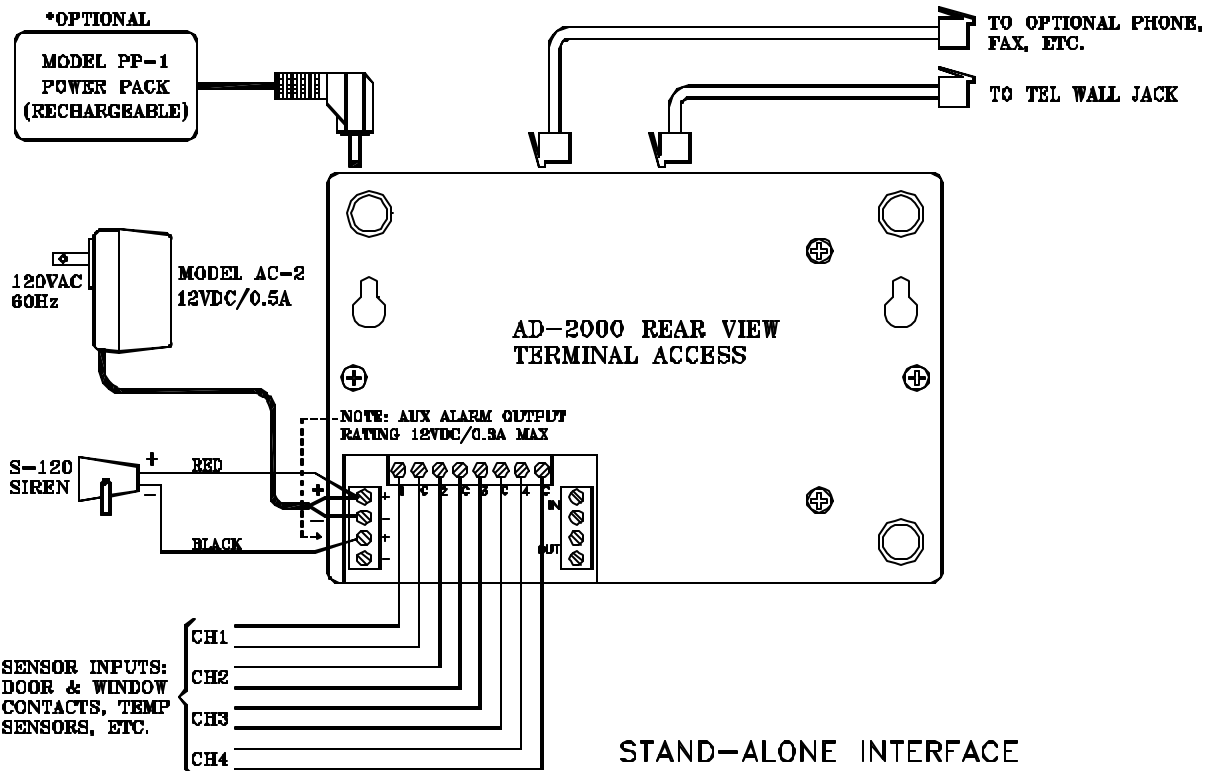

PROGRAMMING THE DIALER

Overview

Please study this section thoroughly before beginning to program the dialer, referring to the Sample Program Planner on page 13. Then, select from among the options for each feature, listing each choice in pencil on the blank Program Planner on page 14. Once the dialer is correctly programmed, list each choice in ink. One copy of the Planner should be kept by the installer; one copy should remain with the end user.

A look At The Keypad

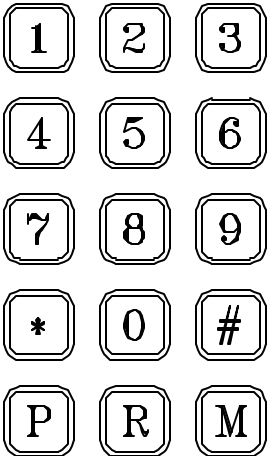

- **CALLOUT FOR NUMERALS:**

Press these keys to enter telephone numbers and other programming information as specified in this manual. A maximum of 50 digits can be input in each phone/pager location.

- **CALLOUT FOR P:**

Press this key to program in a pause. Each "P" provides a 2-second pause.

- **CALLOUT FOR R:**

Press this key to record the combination of identification and directional outgoing messages (OGMs). The total elapsed OGM time cannot exceed 51 seconds.

- **CALLOUT FOR M:**

Press this key to change the Mode of the dialer, in sequence:
PROGRAM TEST OPERATE OFF.

Once the unit has been programmed, removing power or placing the dialer in the OFF mode will not affect the programming.

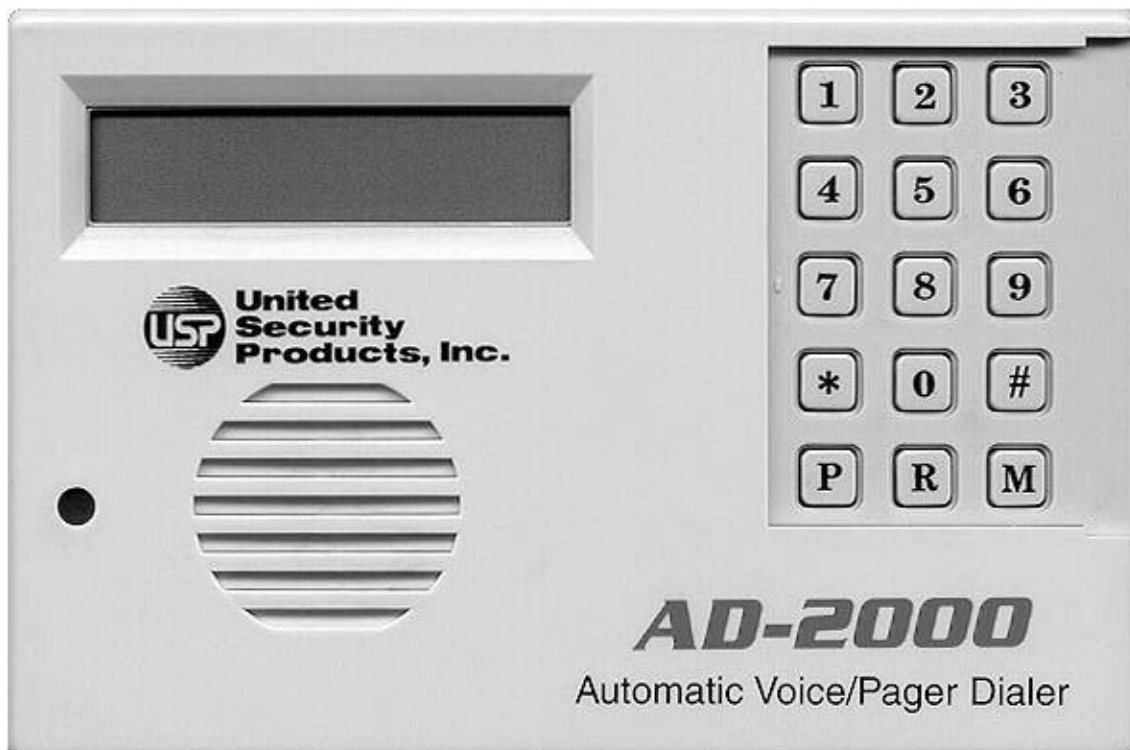

PROGRAMMING THE DIALER

First Time Installation to Initialize Dialer Follow Steps 1 & 2.

STEP 1 Apply power to the unit.
The LCD will read:
NOT PROGRAMMED
PRESS KEYPAD #1

STEP 2 Press 1.
The LCD will change to read:
USP AD2000 X.X
then: PROGRAM: NUMBERS
then: SELECT: 1-8
0(DONE)

Programming Telephone And/Or Pager Numbers

You are now ready to begin programming the dialer. All programming can be input before connecting the dialer to a telephone line. Check the unit's LCD as you program numbers in the dialer to ensure accuracy. Please complete all programming instructions before attempting to operate the unit.

Before programming your dialer to call the police, fire department or 9-1-1 directly, you must check with these agencies for their approval.

A maximum of 50 digits (including pauses) can be programmed in at each location.

***PROGRAM: NUMBERS** **SELECT: 1-8**
1(YES) 2(NO) **0(DONE)**

*This prompt will appear after a number has been programmed and this section has been exited.

STEP 1 Press location number 1-8 to program the first number. This can be any location 1-8. You do not have to program locations in sequence. For example, you can program numbers in locations 3 and 5. **When you are done programming all the desired telephone and/or pager numbers, press "0" to exit this section.**

The LCD will read: **PAGER**
1(YES) 2(NO)

STEP 2 Press "1" if you wish to program in a numeric pager number (step 3A). Press "2" if you wish to program in a telephone number (step 3B), cellular phone number (step 3B), or a voice pager (step 3C).

STEP 3A- NUMERIC PAGERS

NOTE: WHEN PROGRAMMING NUMERIC PAGERS, YOU MUST PROGRAM IN ONE OR MORE PAUSES. EACH "P" PROVIDES A 2-SECOND PAUSE. BEFORE PROGRAMMING IN A PAGER, CALL THE NUMBER TO DETERMINE THE NUMBER OF 2-SECOND PAUSES TO BE PROGRAMMED IN.

If you pressed "1" to program in a numeric pager... Press the digits of the pager to be called. The numbers will appear on the LCD, as will the following key designations. Press "P" one or more times in accordance with the number of seconds needed to accommodate the pager. **(Remember, each "P" provides a 2-second pause).**

Press the digits of the numeric pager code.
NOTE: SOME PAGER SERVICES REQUIRE A "#" SIGN FOR SEPARATION OF THE NUMERIC CODE OR AT THE END OF THE NUMERIC CODE FOR PROPER TRANSMISSION.

Press "*" to store the sequence.
Example: To store numeric pager number 555-1212, a 4-second Pause and code 3456:

Press

5 5 5 1 2 1 2 P P 3 4 5 6 *

STEP 3B – TELEPHONE NUMBERS

If you pressed "2" and wish to program in a telephone number... Press the digits of the number to be dialed. For long-distance numbers, first press "1" followed by the area code and then the number. The number will appear on the LCD. Press "*" to store the sequence.

Example: Store telephone number 1-800-555-1212:

Press:

1 8 0 0 5 5 5 1 2 1 2 *

REMEMBER/NOTE: Before programming your dialer to call the police, fire department or 9-1-1 directly, you must check with these agencies for their approval.

STEP 3C – VOICE PAGERS

If you pressed "2" and wish to program in a voice pager...

Press the digits of the pager to be called.

Press "P" one or more times in accordance with the number of seconds needed to accommodate the pager. **(Remember each "P" provides a 2-second pause).**

Press "*" to store the sequence. The number will appear on the LCD.

Example: To store voice pager 555-1212 and a 4-second pause:

Press:

5 5 5 1 2 1 2 P P *

STEP 4 Repeat steps 1-3 for each number to be programmed in each location. Select any of 8 location numbers in Step 1 (SELECT: 1-8) for each number to be programmed.

STEP 5 When you are done programming all desired telephone and/or pager numbers, press "0" to exit this section.

NOTE: IF YOU ENTER THE WRONG CHOICE, PRESS "M" KEY REPEATEDLY AND RETURN TO THE "PROGRAM MODE", THEN SELECT THE SECTION TO CHANGE ("1" ACCEPT SECTION, "2" FOR NEXT SECTION). THEN ENTER CORRECT INFORMATION.

PROGRAMMING THE DIALER

Programming Auxiliary Information

The dialer is preset at the factory to typical telephone line (T-LINE), PBX, Dialing Attempts and Message Repeat options. If you choose to accept the following default prompts, simply press “2” to scroll to the next section. **If your phone system requires dialing a digit to get an outside line or dial tone, similar to PBX, then turn PBX on and enter digit to program.**

PRESETS

T-LINE.....TONE
PBX.....OFF
ATTEMPTS.....2
MESSAGE.....2

To change the presets, follow these steps.

T-LINE

The LCD will display: **PROGRAM: T-LINE**
1(YES) 2(NO)

Press “1” to program T-LINE.

Press “2” to scroll to the next section.

The LCD will display: **PROGRAM: T-LINE**
1(TONE) 2(PULSE)

Press “1” for TONE. Press “2” for PULSE.

PBX

The LCD will display: **PROGRAM: PBX**
1(ON) 2(OFF)

Step 1: Press “1” for ON. Press “2” for OFF.

Step 2: If “1” is entered, the LCD will display:

PROGRAM: PBX
ENTER PBX NUMBER

Enter PBX number (1 digit).

ATTEMPTS

ATTEMPTS refers to the number of times the dialer will call each designated number. Both successful and unsuccessful (busy or no answer) call are considered attempts.

The LCD will display: **PROGRAM: ATTEMPTS**
ENTER 1-9

Step 1: Press the digit (1-9) corresponding to the number of times you wish the dialer to call each number.

MESSAGE

MESSAGE refers to the number of times each message will be delivered to each designated number.

The LCD will display: **PROGRAM: MESSAGE**
REPEAT ENTER 1-3

Step 1: Press the digits (1-3) corresponding to the number of times you wish the message(s) to be delivered.

After selecting the number of message repeats, the dialer will automatically exit this section.

Structuring Your Outgoing Messages

The AD-2000 dialer was designed with optimum versatility and functionality in mind. Nowhere is this more apparent than in the matrix of outgoing messages (OGMs). The user’s ability to “mix and match” OGMs allows complete system customization and provides ultimate efficiency.

Total OGM time is 51 seconds.

A beginning identification (ID) message of up to 15 seconds can be programmed in (options #4, #6, and #8). Your ID message should clearly state your name, address and other pertinent emergency information.

Typically, each OGM will have a specific purpose. For instance, OGM 1 can alert the person notified to contact the fire department while OGM 2 can alert the person to contact the police department. Typically the dialer is programmed to notify family, friends or another responsible party. Before programming your dialer to call the police, fire department or 9-1-1 directly, you must check with these agencies for their approval.

OPTION #1 No OGM. Select this option if you do not wish to record any outgoing messages.

OPTION #2 1 OGM. Select this option if you wish to record one OGM, which may be as long as 51 seconds.

OPTION #3 2 OGMs. Select this option if you wish to record two OGMs, each of which may be as long as 25.5 seconds.

OPTION #4 ID plus 2 OGMs. Select this option if you wish to record one ID of up to 15 seconds in length, and two OGMs, each of which may be as long as 18 seconds.*

OPTION #5 3 OGMs. Select this option if you wish to record three OGMs, each of which may be as long as 17 seconds.

OPTION #6 ID plus 3 OGMs. Select this option if you wish to record one ID of up to 15 seconds in length, and three OGMs, each of which may be as long as 12 seconds.*

OPTION #7 4 OGMs. Select this option if you wish to record four OGMs, each of which may be as long as 12.75 seconds.

OPTION #8 ID plus 4 OGMs. Select this option if you wish to record one ID of up to 15 seconds in length, and four OGMs, each of which may be as long as 9 seconds.*

*If your ID message is less than 15 seconds in length, the remaining time will be evenly divided among the OGMs.

Example: OPTION #4: ID plus 2 OGMs.

If the ID is 10 seconds, then each OGM can be (51 minus 10 equals 41 divided by 2 equals) 20.5 seconds in length.

PROGRAMMING THE DIALER

Programming And Recording Your Outgoing Messages

Follow these steps to program and record your outgoing messages. Skip this portion if you have programmed in only numeric pagers, which rely on coded DTMF messages. As with all AD-2000 programming, the unit need not be connected to a phone line when information is programmed in. Remember that "OPT" on the LCD stands for option; "OGM" stands for outgoing message.

NOTE: IF YOU ENTER THE WRONG CHOICE, PRESS "M" KEY REPEATEDLY AND RETURN TO THE "PROGRAM MODE", THEN SELECT THE SECTION TO CHANGE ("1" ACCEPT SECTION, "2" FOR NEXT SECTION). THEN ENTER CORRECT INFORMATION.

STEP 1 Decide which of the eight options you prefer.

STEP 2 Before programming in this option, write down all your messages. Time them carefully, changing them if necessary to fit the allotted time frame. Practice saying them, clearly enunciating each message for maximum clarity in case of an emergency. Keep a final recording script.

STEP 3 Program your option.

- A) The LCD will read: **PROGRAM: OGMs**
1(YES) 2(NO)
- B) Press "1" to program your OGMs. Press "2" to scroll to the next section.
- C) Press "1" to select the option (#1- #8) displayed or press "2" to scroll to the desired option.

STEP 4 After selecting your option as explained above, record your message.

- A) The word RECORD will appear in the upper left corner of the LCD, above the instruction: PRESS R. The option selected will appear in the upper right corner. For instance, if you selected option #2, the LCD will read:

RECORD OGM1
PRESS R

- B) Speak 6-12 inches away from the microphone. Referring to your script and speaking in a normal voice, press and hold R (the word RECORDING will be displayed), releasing the key after you have completed enunciating your messages. The word DONE will appear on the LCD when the maximum allotted time has been reached.

- C) The LCD will read: **PLAY OGM(S)**
1(YES) 2(NO)

Press "1" to play back your recording

- D) The LCD will read: **ACCEPT**
1(YES) 2(NO)

Press "1" to accept the recorded OGM(s). Press "2" if you wish to re-record the messages, beginning with Step 4.

Changing The OGMs

After your system is up and operating, you may change one or more of the recorded OGMs and/or choose a completely different option. To do so, simply scroll to the programming section on your display: **PROGRAM: OGMs**

1(YES) 2(NO)

Select the option, then begin again from Step 3 above to record your new message(s).

Programming The Channels

The AD-2000 is designed to be adaptable to a complete range of personalized applications. Each of the four input channels can be programmed individually for full system customization. In addition to setting enable/disable options, entry/exit delays and type of activation (N.O., N.C., & momentary or continuous), each user can specify which emergency messages will be delivered and which numbers will be dialed. The first channel activated will be the priority channel. Numbers programmed to that channel will be completed before the dialer moves on to the next channel(s).

Although comprehensive in scope, the system is easy to program. Just follow these simple steps.

NOTE: IF YOU ENTER THE WRONG CHOICE, PRESS "M" KEY REPEATEDLY AND RETURN TO THE "PROGRAM MODE", THEN SELECT THE SECTION TO CHANGE ("1" ACCEPT SECTION, "2" FOR NEXT SECTION). THEN ENTER CORRECT INFORMATION.

STEP 1 The LCD will read: **PROGRAM: CHANNELS**
1(YES) 2(NO)

Press "1" to begin programming the channels.

STEP 2 The LCD will read: **SELECT: 1-4**
0(DONE)

Enter the channel you wish to program (1-4).

Enable/Disable

STEP 3 The LCD will read: **CH X: ENABLE**
1(YES) 2(NO)

("CH X" being the channel selected)

Press "1" to enable the channel. Press "2" to disable the channel.

Exit/Entry Delays

Capable of programming up to a maximum of 3 minutes and 20 seconds each.

STEP 4 The LCD will read: **CH X: EXIT DELAY**
1(YES) 2(NO)

Proceed with A) if you wish to program an exit delay.

Proceed with B) if you do not.

- A) To program exit delay, press "1".

The LCD will read: **ENTER 0-199 THEN**
PRESS *

Enter the digits corresponding to the number of seconds you wish to install. (For example, press "120" then press "*", if you wish to install a 120-second exit delay).

- B) If you do not wish to program an exit delay, press "2".

STEP 5 The LCD will read: **CH X: ENTRY DELAY**
1(YES) 2(NO)

Proceed with A) if you wish to program an entry delay.

Proceed with B) if you do not.

- A) To program an entry delay, press "1".

The LCD will read: **ENTER 0-199 THEN**
PRESS *

Press "1" to program a delay. Then enter the digits corresponding to the number of seconds you wish to install. (For example, press "90" then press "*", if you wish to install a 90-second delay).

- B) If you do not wish to program an entry delay, press "2".

PROGRAMMING THE DIALER

Normally Open/Normally Closed

STEP 6 The LCD will read:

CH X: N.O./N.C.
1(N.O.) 2(N.C.)

- A) Press "1" to select a normally open channel.
- B) Press "2" to select a normally closed channel.

Momentary/Continuous Activation

STEP 7 The LCD will read:

CH X: MOM/CONT
1(MOM) 2(CONT)

- A) Press "1" to select a momentary trigger.
- B) Press "2" to select continuous activation.

Numbers Dialed/Outgoing Messages

Following these steps allows you to choose which OGM(s) will be delivered and which numbers will be dialed for each channel. NOTE: Dialer LCD will only show programmed numbers and OGM options.

STEP 8 The LCD will read:

CH X: DIAL #X
1(YES) 2(NO)

("Dial #X" being the number in phone/pager location 1-8)

- A) Press "1" to dial phone/pager #X to be dialed when the selected channel is activated. Press "2" if you do not wish this number to be dialed.

- B) Continue the above procedure for each of the up to eight phone/pager numbers programmed in.

STEP 9 The LCD will read:

CH X: OGM X
1(YES) 2(NO)

("OGM X" being the OGM recorded in OGM options #2 - #8)

- A) Press "1" to deliver OGM X when the channel is activated. Press "2" if you do not wish this OGM to be delivered.
- B) Continue the above procedure for each Channel/OGM. If you have programmed in and recorded an ID message as one of your OGM options, this ID will be delivered to all channels. It will not appear in the Channel display.

NOTE: ID AND OGM(S) WILL ONLY BE DELIVERED TO TELEPHONE NUMBERS, CELLULAR NUMBERS, AND VOICE PAGERS.

Completing The Programming

Once you have programmed in all dialing and OGM options for each channel, the LCD will read:

ACCEPT
1(YES) 2(NO)

STEP 10 Press "1" to accept the Channel programming. Press "2" to re-program or to revert to previously programmed setting.

You are now ready to review your programming and test the system.

PRESS "M" TO EXIT PROGRAMMING MODE.

TESTING YOUR SYSTEM

Test your system before an emergency occurs.

Do not neglect to review programmed information and verify all elements of your system thoroughly before relying on the dialer to deliver the necessary information to the desired parties accurately and completely.

We strongly recommend testing the system in test mode before connecting to a telephone line. The test mode tests the stored information, not the full functionality of the dialer. To test the full functionality of the dialer, the unit must be tested in the operate mode. In the test mode, the dialer will not make more than one attempt per number dialed or play any OGM more than once.

NOTE: IF YOU ENTER THE WRONG CHOICE, PRESS "M" KEY REPEATEDLY AND RETURN TO THE "PROGRAM MODE", THEN SELECT THE SECTION TO CHANGE ("1" ACCEPT SECTION, "2" FOR NEXT SECTION). THEN ENTER CORRECT INFORMATION.

STEP 1 Press the "M" Mode key until the LCD reads:

TEST: T-LINE
1(YES) 2(NO)

STEP 2 Press "1" to display the T-Line configuration.

The data will scroll through all selections.
Press "2" to scroll to the next section.

STEP 3 The LCD will read:

TEST: CHANNEL(S)
1(YES) 2(NO)

Press "1" to test channels.

Press "2" to scroll to the next section.

STEP 4 The LCD will read:

SELECT: 1-4
5(ALL) 0(DONE)

Select the channel you wish to test (1-4). Press "5" to test "all" Channels. Once a channel is selected (or "all") the programmed channel information will be displayed on the LCD. Verify data accuracy as the LCD scrolls through by comparing the information displayed with that specified on your Program Planner. Listen to your recorded message(s) to ensure that the correct OGM (if programmed) is delivered. Press "0" to exit testing.

STEP 5 Now connect your dialer to the telephone line you will be using and test the system again, to determine if it functions correctly in an actual emergency situation.

Make sure you notify the receiving party of your intent to call them, and tell them it is just a test.

STEP 6 To test the operation of your entire system, set Mode to OPERATE and proceed as explained in the next section: Operating Your System.

Test your system on a regular basis, at least once a week.

OPERATING YOUR SYSTEM

You are now ready to begin operating your system, relying on the AD-2000 to work in conjunction with your alarm system to provide 24-hour security reassurance and peace of mind.

When in the operating mode, the system will monitor all the enabled channels, initiating dialing when a valid alarm condition occurs. Upon activation the dialer will begin calling each phone/pager number selected, in sequence, for the pre-selected number of attempts. During each successful attempt, the voice message will be delivered 1, 2, or 3 times, in accordance with the option selected (**numeric messages will only be delivered one time**). In unsuccessful attempts, the dialer will move on to the next phone/pager number after receiving 8 busy or 8 rings without an answer. The dialer will not allow voice messages to be delivered to programmed numeric pager locations.

If you send a message to a phone attached to an answering machine, it will consider this a successful attempt. Make sure you designate the maximum number of message repeats to be sure that a complete message will be left on the answering machine, because part or all of your emergency message may be “lost” while the answering machine delivers its greeting message.

Placing your system in OPERATE can also be used as a final test of the full functionality of each channel’s exit/entry delay, activation, momentary/continuous trigger, phone numbers and OGM. Although serving as a test, this mode reflects actual operation; therefore the OGM(s) will not be heard through your dialer’s speaker but only by each party called.

To begin operating your system, simply press the “M” Mode key until the word OPERATE appears on the LCD. To disarm the dialer, switch the mode to OFF by pressing the same key. All programming information will be retained

System Notations

Here are a few explanations to help you better understand how your AD-2000 dialer operates. For specific information on the AD-2000 unit alone, call United Security Products, Inc.’s Customer Service Department during normal business hours at (858) 597-6677.

Channel Activation

Each of the dialer’s four channels can be activated by any of the following: a normally open dry contact, normally closed dry contact or positive 5-28VDC voltage activation.

Under a momentary activation, a single violation of a channel will cause the dialer to initiate delivering all pre-selected OGMs to all programmed numbers associated with that channel. Under continuous activation, the dialer will initiate the process, terminating it if/when the activated channel is restored to a non-alarm state. Once an alarm has occurred and all attempts satisfied, the dialer will continue to monitor any remaining enabled channel(s). Once the activated channel has been restored to a non-alarm state, it will then be re-armed and ready for the next alarm.

Exit/Entry Delays

If a channel is activated during a pre-selected exit delay, the alarm condition will be ignored until the delay has expired. If an alarm occurs, the entry delay will cause the dialer to wait before starting the dialing process. **To de-activate the dialer during the entry wait period, simply press “M” to return to the OFF Mode.** Both exit and entry delay times can be pre-selected to range from 1-199 seconds.

Additional features

The dialer offers three innovative features that enhance the utility of the entire system.

Listen-In

While receiving an OGM on a touch-tone phone, the called party can press “1” to listen in to the activity at the other end of the line for one minute. Pressing “1” again restarts the minute increment period and can be repeated indefinitely. When “1” is pressed the OGM will stop playing and the listen in period will start.

Two-Way

After the called party is listening-in, that party can press “2” to begin a two-way conversation lasting for one minute. This procedure also can be repeated indefinitely by pressing “2” again to restart the minute. Once you are in two-way mode you cannot go back to Listen-In.

Remote Turn-Off

The called party can remotely terminate the activated channel any time during the OGM by pressing “1” then “#” twice within one second. The dialer will continue to monitor the remaining channel(s). Once the terminated channel is restored to a non-alarm state, it will re-arm. If in listen-in or two-way, simply press “#” twice in one second, for remote turn-off.

Sample Program Planner

PROGRAM: NUMBERS

NUMBER									
1			✓						
2									
3									
4									
5	✓								
6	✓								
7									
8									

✓			✓				

✓									

✓		✓			✓			✓	✓		✓		✓		✓		✓		✓
	✓		✓			✓			✓	✓		✓		✓		✓		✓	

Programming Example for Quick Setup

Before programming the dialer, study the example shown on this page. This “quick setup” example programs in one telephone number, two numeric pager numbers, two attempts, two repeats, an ID plus two additional OGMs, and channels 1 and 4.

Once you understand the setup, use the blank Program Planner on page 14 to begin programming your dialer. We recommend making several blank copies of the Planner before beginning the process. It also is advisable to fill in the Planner in pencil initially.

STEP 1 Press “1”.

STEP 2 When the LCD reads SELECT 1-8, press “1” to install the first phone number in location 1 press “2” to indicate no pager; then press, in sequence, (fictitious) phone number “2345678” followed by the “*” sign to store the programming process for that number.

STEP 3 Press “5” to install the second phone number in location 5; press “1” to indicate numeric pager; then press, in sequence, “3456789PP4455#” followed by the “*” sign. The first seven digits represent the pager number dialed; each P stands for a 2-second pause; the next four digits followed by the # sign represent the pager code and the * stores the programming process for that number.

Now press “6” to install the third phone number in location 6; press “1” to indicate numeric pager; then press, in sequence, “3456789PP5544#” followed by the “*” sign.

STEP 4 Press “0” to exit PROGRAM NUMBERS.

STEP 5 At the PROGRAM: T-LINE prompt, press “1” to choose tone; press “2” to indicate no PBX; press “2” to program in two dialing attempts per emergency number called; press “2” to program in two message repeats for each call.

STEP 6 Press “1” to PROGRAM OGM(S). Press “2” three times to Scroll to option #4; press “1” to program in an ID message and two

specific outgoing messages (OGMs).

STEP 7 Using a prepared script and speaking six-to-eight inches from the dialer’s microphone on the front of the unit, press “R” when you are ready to enunciate your 15-second identification message and your two 18-second messages. Dialer automatically prompts to next OGM. Make OGM1 a message telling the receiving party to call the police department. Make OGM2 a message to call the fire department.

STEP 8 Press “1” to play back all recorded messages; press “1” again to accept. (**NOTE: DIALER LCD WILL ONLY SHOW PROGRAMMED NUMBERS AND OGM OPTIONS.**)

STEP 9 Press “1” to PROGRAM CHANNELS.

STEP 10 Press “1” to program Channel 1. Press “1” to ENABLE. Press “1” then enter “30” then press “*” for a 30-second EXIT delay; press “1” then enter “15” then press “*” for a 15-second entry delay. Now press “2” for NORMALLY CLOSED and then “1” for MOMENTARY activation. Press “1” to select phone/pager number 1 to be dialed. Press “1” again to select phone/pager number 5 to be dialed. Press “2” to **not** select phone/pager number 6 to be dialed. Press “1” to select OGM1 to be delivered and press “2” to **not** select OGM2 to be delivered. Press “1” to accept the channel configuration.

STEP 11 Press “4” to program Channel 4. Press “1” to ENABLE. Press “2” twice to indicate no EXIT or ENTRY delay. Now press “1” for NORMALLY OPEN and the “2” for CONTINUOUS activation. Press “1” to select phone/pager number 1 to be dialed. Press “2” to **not** select phone/pager 5 to be dialed. Press “1” to select phone/pager number 6 to be dialed. Press “2” to **not** select OGM1 to be delivered and press “1” to select OGM2 to be delivered. Press “1” to accept the channel configuration.

STEP 12 Press “0” to exit PROGRAM: CHANNELS.

Press “M” to exit programming mode.

SPECIFICATIONS

Dimensions

Power source:	9-18VDC
Current (OPERATE mode – standby):	28mA typical.
Current (OPERATE mode – dialing):	100mA max.
Activation:	1) N.C. Activation: dialer activates when an “open” is detected 2) N.O. Activation: dialer activates when a “close” is detected 3) Voltage Activation: N.C. (applied voltage: Min. +5VDC, Max. +28VDC) N.O. (loss of continuous voltage: Min. 0VDC, Max. 0.25VDC)
Max. digits for outgoing numbers:	50
Operating temperature range:	-18 to 55 C (0 to 130 F)
Dimensions (inches):	6 x 4 x 1.5 in
Weight (ounces):	10 oz
Mounting:	Wall or Flat Surface
Case Material:	ABS
Color:	White
Warranty:	1 Year

Note: Design and specifications subject to change without notice.

DIALER ACCESSORIES

Power Source

AC-1: AC/DC Adaptor

Plugs into regular 110VAC outlet to provide the dialer with the required primary power.

AC-2: AC/DC Adaptor

12VDC/0.5A for stand alone with siren use.

PP-1: Power (Rechargeable)

Provides 24 (est.) hours of backup standby power.

AC-1P: AC/DC Adaptor For Use With PP-1

Plugs into regular 110VAC outlet to provide the dialer with the required primary power and additional input for PP-1 interface.

IR-1: Isolation Relay

Converts alarm output voltage to N.C. to provide clean input trigger to dialer.

Industrial/Residential Sensors

F20: Temperature Supervisory Switch <40 F

HTS: High Temperature Switch

LTS: Low Temperature Switch

CSS: Cold Storage Switch

WLS: Water Level Sensor

RTS: Adjustable Temperature Controller, N.O., N.C.

PLS: Power Loss Sensor (110VAC)

Sensors

Magnetic Contacts – Door and Window

Glass Break Detectors

Hold Up Buttons/Emergency Switches

Pressure Mats – Sealed and Under Carpet

Motion Detectors

Siren

S-120: 2” Mini Siren, 12VDC @ 120 mA typical

Additional Options

Data logger: AD-2001-DL

Retains in memory log of alarm events for later retrieval and review.

Wireless: AD-2000/W

Wireless version AD-2000 dialer includes wireless pendant transmitter.

24V Application: AD-2000/F

For this option the dialer is configured to operate at 24VDC to 32VDC max. All other specifications apply.

Wireless and 24V Applications: AD-2000/W/F

The AD-2000/W/F incorporates both the wireless feature and 24VDC application. See WIRELESS AND 24V APPLICATION for further details.

NOTE: CALL UNITED SECURITY PRODUCTS FOR ADDITIONAL INFORMATION AND DEVICES NOT LISTED HERE.

Wireless Upgrade:

The standard AD-2000 can be upgraded for wireless link-up with RF-activated mag contacts, motion sensors, pendant, etc., by installing a new back cover containing a pre-tested RF assembly and swivel antenna. The receiver is connected to the main board via a 4-pin interface connector already included in the standard configuration. See WIRELESS for further details.

NOTE: SYSTEMS ALREADY INSTALLED CAN BE UPGRADED WITHOUT REPLACING OR RE-WIRING THE DIALER.

IMPORTANT INFORMATION

Care And Precautions

LOCATION

Place the dialer on a flat level surface or mount the unit on the wall, away from extreme cold or heat, direct sunlight, excessive humidity and away from equipment that generate strong magnetic fields. Avoid placing near large metal objects and areas that produce smoke, dust and mechanical vibrations.

CARE

Clean the housing with a soft cloth lightly moistened with water or mild detergent solution. Never use solvents such as alcohol or thinner. Do not allow liquids to spill into the unit.

OPTIONAL BACKUP

To ensure continuous operation during power outages, hookup to a 12VDC backup battery pack is recommended. (PP-1) Available from United Security Products.

CAUTION

Do not use the dialer if a gas leak is suspected or during lightning.

PROBLEMS

If liquid or a foreign object penetrates the unit, disconnect it immediately and contact your installer or other qualified technician.

Before calling USP, please make sure...

- You have read this manual and understand how to operate the dialer.
- Your phone line is working.
- You check out the entire system, including external hookup wiring and sensors attached.

If you still have questions or concerns, call our USP Technical Service Department between the hours of 7:30 AM and 4:00 PM, PST, Monday through Friday.

Federal Communications Commission Radio And Television Interference Statement For A Class 'B' Device

This equipment generates and uses radio frequency energy and if not installed and used properly, that is, in strict accordance

with the manufacturer's instructions, may cause interference to radio and television reception. It has been type tested and found to comply with the limits for a Class 'B' computing device in accordance with the specifications in Subpart B of FCC Rules and Regulations (as outlined in the Code of Federal Regulation, Title 47), which are designed to provide reasonable protection against such interference in a residential installation.

User Instructions

If this equipment does cause interference to radio or television reception, which can be determined by turning the equipment off, then on, the user is encouraged to try to correct the interference by one or more of the following measures:

- Reorient or relocate radio or television.
- Increase the separation between the equipment and receiver.
- Connect the equipment into a different outlet so that the equipment and receiver are on different branch circuits.
- Consult the dealer or an experienced radio/TV technician for help.

Changes or modifications not expressly approved by United security Products, Inc. could void the user's authority to operate the equipment.

AD2000 SERIES FAQ SHEET

1. Can the dialer be used as a stand-alone unit?

Yes, Purchase USP part# PB12P to provide both main power and battery backup. The PB12P plugs right into the 12vdc input jack on top of the dialer. USP's warranty does not cover reverse polarity or lightning strikes and other acts of God. When using electrical devices, we recommend using surge protection for any voltage feeding into this unit ,i.e. phone line, power source, etc..

2. Can the dialer be programmed to isolate certain phone numbers to one or more inputs?

Yes. By programming your channel inputs, you can determine which numbers you want to be called out when a channel is activated.

3. Can the dialer call my numeric pager or cellular phone?

Yes. Depending on the pager service, a delay may have to be inserted between the pager number and the pager code followed by a #, before entering the*. The pager number can be programmed for multiple pauses (each I pause is 2 seconds long) for a longer delay. For cellular phones it is recommended to add six pauses after the number before pressing *. Numbers can be programmed for multiple "pauses" (each "pause" is 2 seconds long) for a longer delay. See manual for more information on programming numbers.

4. How do I program the dialer for use with a PBX system?

Simply program the T-LINE for PBX ON and enter the digit that will acquire the outside line. This PBX number is universal for all programmed numbers. Once the dialer is activated, the dialer will issue the PBX number 50ms after connecting to the line, then wait for a dial tone and begin dialing.

5. How do I incorporate line seizure into my hookup?

You can use either the RJ11 jacks or the IN/OUT terminals inside the dialer. Connect the main telephone line to the LINE IN (RJ11) jack or IN terminals, then connect the phone to the LINE OUT (RJ11) or OUT terminals.

6. Why does my message sound garbled or muffled?

When you record your OGM, be sure to position yourself no closer than 2 inches but no further than 15 inches away from the dialer. Try to eliminate any background noise.

7. How can I erase phone numbers or change voice messages from the dialer memory?

Program over the existing phone number or do not select that phone number when programming the channels. For voice, record over the existing message.

8. How do I activate my dialer?

The dialer can be activated by a momentary or continuous input, a N.C. or N.O. dry contact (that either opens or closes in an alarm condition) or a voltage level/pulse.

9. Why doesn't my dialer activate when I apply a +12VDC on the input(s)?

The 1K-ohm resistor (provided) needs to be installed across the alarm output terminals of the alarm panel or across the input terminals of the dialer (such as; 1 and C). Program the specified input for Normally Closed (N.C.) activation. Dialer will activate once the input senses a voltage of 5-28VDC.

10. Why doesn't my dialer activate when I remove the applied +12VDC on the input(s)?

The 1K-ohm resistor (provided) needs to be installed across the alarm output terminals of the alarm panel or across the input terminals of the dialer (such as; 1 and C). Program the specified input for Normally Open (N.O.) activation. Dialer will activate once the input senses that the voltage has been remove.

11. How can I install my dialer to work with a relay?

Attach the input leads of the dialer to the relay as follows: For Normally Closed activation; Input from dialer (such as; 1) to the Normally Closed (N.C.) terminal of the relay and common (C) from the dialer to common (C) on the relay. For Normally Open activation; Input from dialer (such as; 1) to the Normally Open (N.O.) terminal of the relay and common (C) from the dialer to common (C) on the relay. The coil of the relay needs to be connected to the alarm output.

12. Can I stop the dialer from continuing the dialing sequence once a dialing attempt is successful?

Yes. While the OGM is playing, press "1" on the touch tone phone, then press the "*" twice within 2 seconds to initiate the Remote Turn Off (RTO) feature. Once the alarm input has been restored to the non-alarm state, the input will then be re-armed.

